

MS3509 Technical Specification

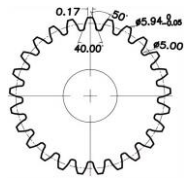

25T-6mm
Output Shaft Spline

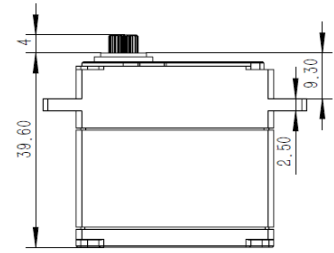
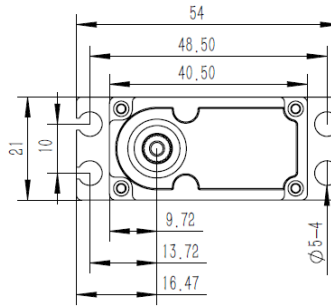

1. Operating Data

Rated Voltage	DC7.4V
Voltage Range	DC6.0V-8.4V
Torque	30Kgf.cm@6.0V
	32Kgf.cm@7.4V
	35Kgf.cm@8.4V
Speed	0.14sec/60°@6.0V
	0.13sec/60°@7.4V
	0.12sec/60°@8.4V
Working	1520us/333Hz
Default Travel	± 100°=200°Total
Temperature	-10°C.....+65°C
Case Material	Aluminum Alloy
Motor Type	Coreless DC Motor
Gear Set Material	Hardened Steel
Position Sensor	Contactless
Ball Bearing	2 BB
Case Dimensions	40.5*21*39.6mm±0.2mm
Weight	78g±10%

2. Performance

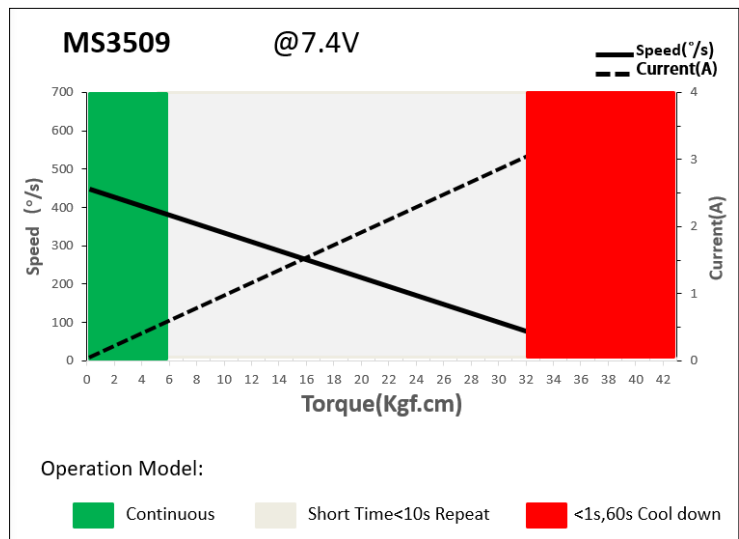

3. Command signal

PWM Command Interface

Signal Voltage	TTL-level: HIGH: min.3.3V, max.5.0V Low: min.0.0V, max.1.5V
Pulse Lengths	500us-2500us
Pulse Lengths for Position	1000us/1500us/2000us -50° 0°+50°

4. Electrical Connection

Pin Assignment (PWM)				
	1	Yellow	SIG	Command Signal
	2	Red	DC+	Supply Voltage
	3	Brown	DC-(GND)	Supply Ground, Signal Ground