

X06N V6.0 Technical Specification

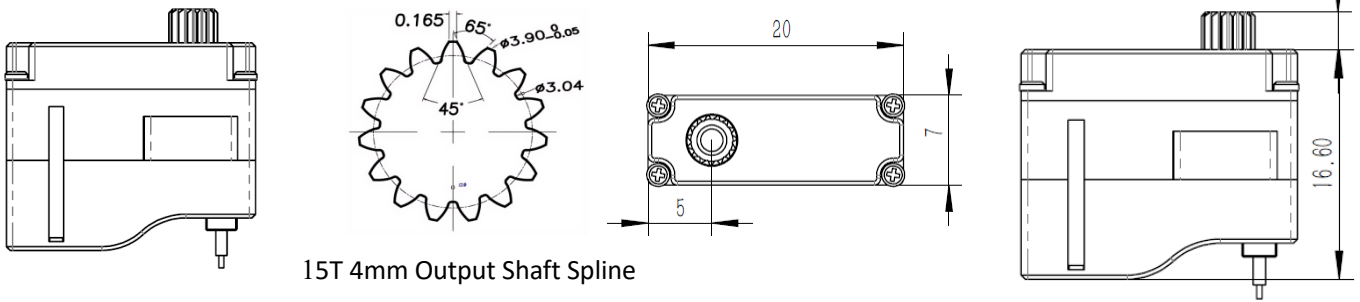

1. Operating Data

Rated Voltage	DC6.0V
Voltage Range	DC3.8V-8.4V
Stalling Torque	0.80Kgf.cm@3.8V
	1.50Kgf.cm@6.0V
	1.80Kgf.cm@8.4V
No-load Speed	0.12sec/60°@3.8V
	0.08sec/60°@6.0V
	0.07sec/60°@8.4V
Stalling Current	0.58A@6.0V
Rated Torque	4N.cm@6.0V
Rated Current	0.22A@6.0V
Rated Speed	0.20sec/60°@6.0V
Working Frequency	1520us/20KHz
Default Travel Angle	±60° = 120° Total
Temperature Range	-10°C+65°C
Soft Start	Yes
Programmable	Yes
Case Material	Aluminum Alloy
Motor Type	Coreless DC Motor
Gear Set Material	Hardened Steel
Position Sensor	Potentiometer
Ball Bearing	1BB
Case Dimensions	20*7*16.6mm±0.2mm
Weight	6g±10%

2. Performance

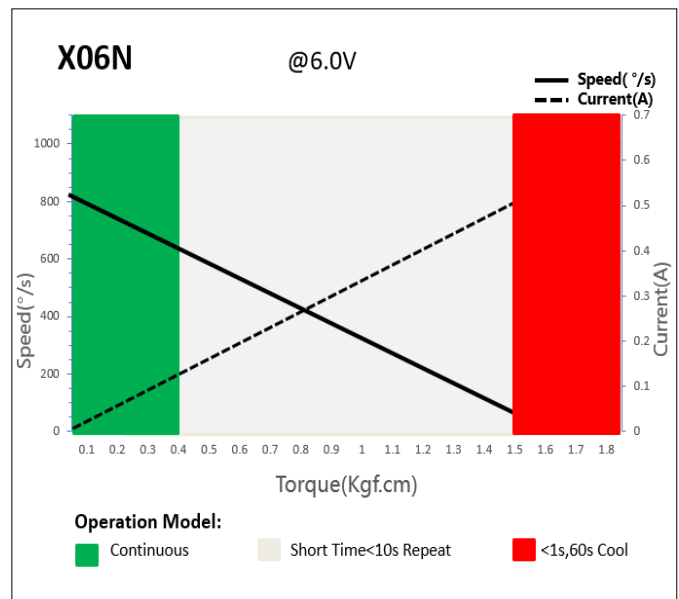

3. Command signal

PWM Command Interface

Signal Voltage	HIGH: min.3.3V, max.5.0V Low: min.0.0V, max.1.5V
Pulse Lengths	900us-2100us
Pulse Lengths for Position	1000us/1500us/2000us -60°/ 0°/+60°

4. Electrical Connection

<p>3 2 1</p>	Pin Assignment			
	1	Orange	Signal	PWM Command
	2	Red	DC+	Supply Voltage
	3	Brown	DC-	Supply Ground